

TANK and IBC

INSPECTION GUIDE

SPECIFIC INSTRUCTIONS ON HOW TO PERIODICALLY CHECK FOR
STRESS CRACKING CAUSED BY CHEMICALS, HANDLING ABUSE &
ENVIRONMENTAL DEGRADATION

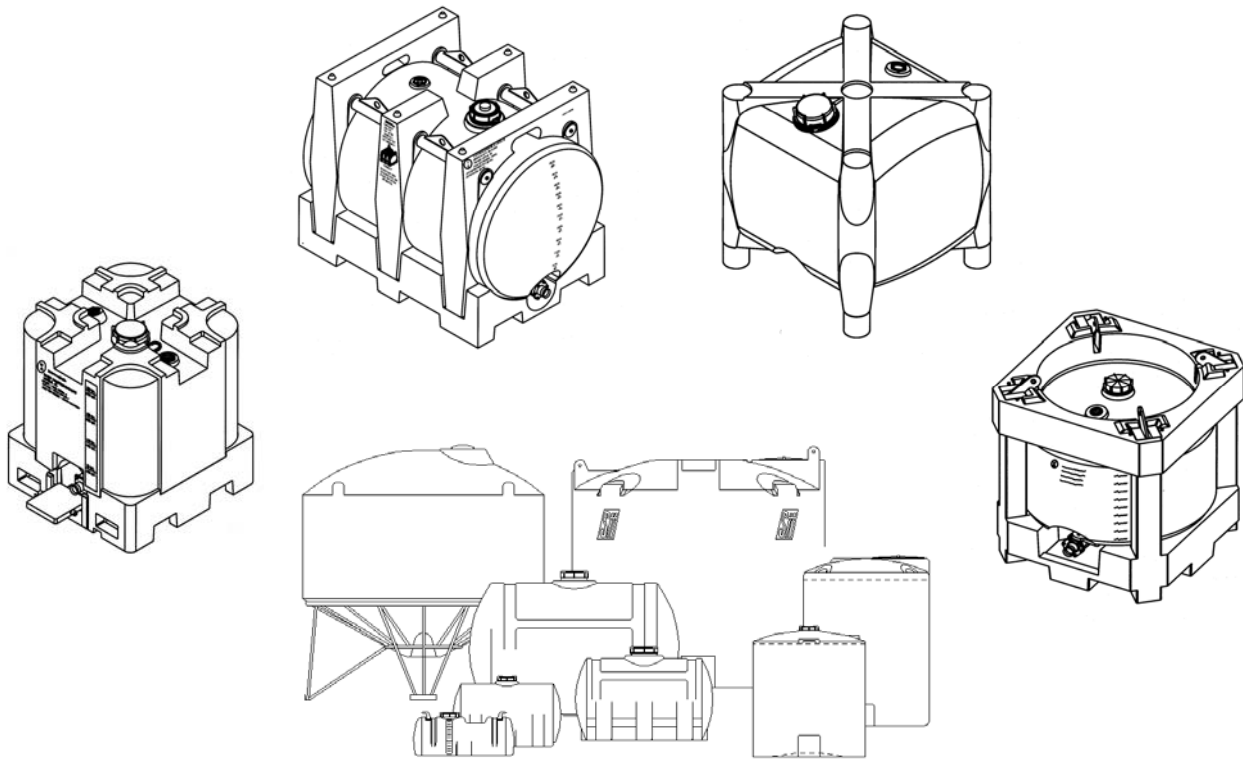

Provides the same capability for checking your liquid bulk storage and transport tanks!



P.O. Box 4583 • Lincoln, Nebraska 68504 • 402-467-5221 • FAX: 402-465-1220 • www.snydernet.com
Other manufacturing locations: Marked Tree, Arkansas • Roanoke, Alabama • Philippi, West Virginia

Snyder Industries, Inc. Polyethylene Tank and I.B.C. Environmental Stress Inspection Guide
Original Issue date 9/18/00

What is an Environmental Stress Inspection?

As pertains to a molded polyethylene tank or I.B.C. the Environmental Stress Inspection is a simple procedure for periodically examining a tank or I.B.C. for possible evidence of environmental damage. Damage caused by ultraviolet attack, chemical exposure, extreme temperatures, impacts, and other environmental conditions limit the useful life expectancy of all tanks. Environmental Stress Cracking is one of the natural results of the effects of the environment on polyethylene. The environment can also affect gaskets, fittings, valves, caps, and other tank accessories. Environmental Stress, when ignored, can lead to problems and ultimately to the loss of chemical. All polyethylene tanks should be checked periodically, using the procedure outlined below.

Environmental Stress Inspection Procedure:

- A. Visually inspect the tank for obvious cuts, cracks, punctures, or leaks that could contribute to tank failure. Look for signs of extensive brittleness, swelling, or softening of the tank walls. Extensive brittleness could be determined by observation of a break, crack, or missing portion of the molded tank. Swelling would be apparent if a tank is deformed in a manner not consistent with the accepted normal deflections seen when the tank is filled. Softening of the tank walls would be observed by pressing on the surface of the tank. A spongy feel to the material could indicate that the material is being degraded or permeated by the contents of the tank. Permeation of the tank wall by a chemical can sometimes be seen as a discoloration of the tank wall penetrating the surface of the material. This discoloration will continue into the wall to the depth of the permeation of the chemical. Permeation can cause a discoloration of the entire thickness of the tank wall once permeation has reached the outer surface of the container. The effects of permeation on the polyethylene tank wall may range from no serious effect to a complete breakdown of the physical properties of the material. Appearance of any of these symptoms should be considered a cause for concern and proper precautions should be taken up to and including removal of the tank from service.
- B. Inspect all fittings for broken parts, excessive corrosion, deteriorated surface texture, and cracks, wear marks, or other signs of potential leaks. Periodic scheduled replacement of fittings may be necessary.
- C. Inspect all gaskets for signs of deterioration. In many cases the gaskets will have a shorter life than the tank itself. Look for discoloration, bulges, checking, or crazing of the gasket material. Many gaskets cold flow, or take a set, and become less effective over a period of time. This can lead to gasket failure or the inability to re-use a gasket after it has been removed. Chemicals also may attack gaskets making proper gasket material selection important. Periodic scheduled replacement of the gaskets may be necessary.
- D. Inspect all valves and/or pumps that may be connected to, or installed in/on, the tank. This inspection should include all hoses and connections. Look for signs of wear, damage caused by impact, misuse, and damage caused by the environment in which the tank is being used. Periodic scheduled replacement of these components may be necessary.
- E. Check for Environmental Stress Cracking of the polyethylene tank or I.B.C. using the following procedure.
 1. Select an area near the top of the tank where environmental stress cracking usually occurs first. In the case of an impact to the tank select the area in which the impact occurred and any surrounding areas which may have been affected. With the test marker provided, or with any black water-soluble marker, mark out an area two or three inches square. Completely ink the entire interior of the square.
 2. With a soft cotton cloth, quickly rub the excess ink off the test area. **DO NOT ALLOW THE INK TO DRY.**
 3. Look for signs of stress cracking which will appear as a web or “crazing” of fine lines that have filled with ink.
 4. Compare the test area with the photos on these pages to determine the degree of stress cracking or impact damage.
 - a) The non-stressed polyethylene photo shows a tank in good condition in the area the test was performed. Check again at the next periodic inspection.



Non-Stressed Poly

Snyder Industries, Inc. Polyethylene Tank and I.B.C. Environmental Stress Inspection Guide
Original Issue date 9/18/00

- b) The evident stress-cracking photo shows a tank displaying definite signs of Environmental Stress Cracking. It is strongly recommended that this tank be replaced.

c)

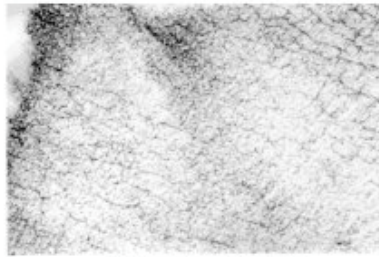

Evident Stress Cracking

- d) The advanced stress-cracking photo shows a tank that has suffered severe environmental damage. Replace tanks with this type of stress-cracking immediately. **DO NOT USE THIS TANK.**

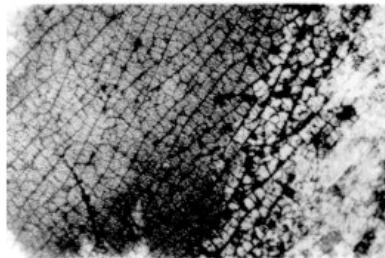

Advanced Stress Cracking

- e) The impact-damaged photo shows a tank that has cracked due to an impact. Replace tanks with this type of damage immediately. **DO NOT USE THIS TANK.**

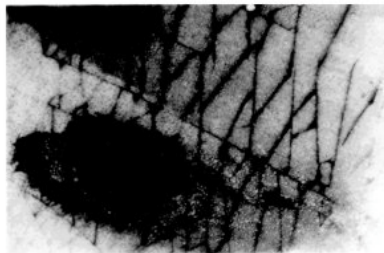

Impact Damaged

- f) The permeation-damaged photo shows a tank that has cracked due to permeation of a chemical through the entire wall thickness of the tank. Replace tanks with this type of damage immediately. **DO NOT USE THIS TANK.**

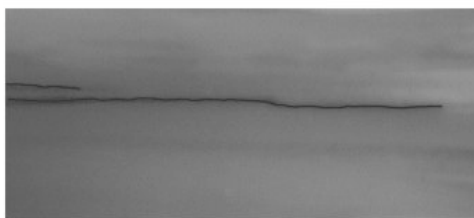

Permeation-Damaged

Snyder Industries, Inc. Polyethylene Tank and I.B.C. Environmental Stress Inspection Guide
Original Issue date 9/18/00

5. Repeat steps 1-4 at these other potentially stressed areas:
 - a) On the sides of the tank.
 - b) Near fittings and outlets
 - c) Where the tank receives the most direct sunlight.
 - d) Corners, edges, lugs, and so forth.
6. Use the following visual light procedure to inspect the entire tank for signs of stress cracking.
 - a) Locate a light source of at least 30 watts. A higher-powered light source will make inspection easier (especially on thicker tank walls). The light source should be a white light (avoid yellow color spectrum lights). Do not let the light source heat the tank material significantly by either direct contact or radiant heat. Keep the light a safe distance from the tank (1-2 feet minimum), and in motion, to avoid spot heating.
 - b) Inspect the tank from the outside (with the light source inside the tank) and from the inside * (with the light source outside the tank) as much as feasible.
 - c) Look for lines with a different light intensity or color than the areas immediately next to the lines. These lines may be stress cracks in the tank material. Investigate any lines more closely with light inspection and feel for material separation at any suspect area. The water soluble marker technique as outlined above may be used to check suspect stress crack areas.
 - d) Inspect potentially stressed areas on the sides of the tank, tank corner/radius, near fittings and outlets, or any area which may have been impacted/stressed abnormally.
 - e) If stress cracks are found, monitor closely and plan for repair or replacement of the tank or I.B.C. (note that the tanks of I.B.C.'s, which are UN marked, cannot be repaired except as allowed in the 49 CFR regulations.

***Warning when entering tanks confined space regulations may apply.**

Please note that this testing should be done in addition to and not in lieu of other standard inspection procedures.

How often should I do Periodic Environmental Stress Inspections?

With the exception of Intermediate Bulk Containers, or other hazardous material transport and storage containers, regulations may not require such inspections. At a minimum it is recommended that all tanks be inspected annually and that a more frequent inspection of tanks in hazardous chemical applications might be necessary. Snyder Industries, Inc. suggests that you determine the frequency of your inspections based on the following environmental considerations.

1. Is the container kept indoors, outdoors, or a combination of both?
In general tanks and I.B.C.'s which are kept outdoors need to be inspected more often due to the effects of Ultraviolet radiation from sunlight. Tanks and I.B.C.'s with a combination of interior and exterior usage would be less affected by Ultraviolet radiation and tanks kept indoors would be the least affected. The geographic location can also affect the exposure to ultraviolet radiation. Locations near the equator or at higher elevations receive greater U.V. exposure than locations nearer the poles or at lower elevations. The environmental stress cracking caused by U.V. exposure is most readily identified by the Environmental Stress Cracking test procedure outlined in item E.
2. Is the container usually filled, usually empty, or continuously filled and emptied?
In most cases a tank which is continuously filled and emptied is more stressed than a tank which is usually filled. A tank which is usually empty is normally the least stressed of all. These stresses are normally found by utilizing Environmental Stress Cracking test procedure outlined in item E.
3. Is the container used as a stationary storage tank, a portable storage tank moved when empty from site to site, or a material transport tank such as an I.B.C.?
Material transport tanks, such as I.B.C.'s, by nature of their usage are generally exposed to a variety of effects not normally encountered by stationary storage tanks. These include damage from improper handling, stresses from vibration during transport, and exposure to differing environments. Storage tanks, transported only when they are empty, are also exposed to greater risk due to

Snyder Industries, Inc. Polyethylene Tank and I.B.C. Environmental Stress Inspection Guide
Original Issue date 9/18/00

transportation considerations, but at lower stress levels than filled tanks. Visual inspections in many cases reveal the damage which might occur during handling and transport. However the transport of a tank can accelerate the environmental stress cracking caused by U.V. or chemical attack, and can be the catalyst that triggers a tank failure. A stress-cracked tank might work in a stationary application for long periods of time and then fail when it is exposed to the stresses incurred during transport and/or handling.

4. Are the contents of the container compatible with the tank and tank component materials? Is the tank or I.B.C. used for only one chemical? Is the tank or I.B.C. used to hold different chemicals at different times? Or is the tank or I.B.C. used to hold mixtures of chemicals?

Generally it is easier to identify the effects of a tank or I.B.C.'s contents on the tank and tank component materials when the tank is dedicated for use with only one chemical for the entire useable life of the tank or I.B.C. container. Some chemicals have little or no effect on the containers or their components while other chemicals may have a limited effect, and still others may severely affect the tank or I.B.C. or the components. Chemical resistance charts can be useful in determining which category a chemical may be in, and what the long-term effects of the chemical on the containers might be. However, these results can be influenced by other factors such as exposure to U.V. radiation, temperature variations, or size of the containers among others. Experience is therefore the most reliable guideline to helping determine the average useful life of a tank or I.B.C. for any chemical application. Tanks and I.B.C.'s used to hold several different chemicals at different times usually fall under the same guidelines as dedicated tanks and I.B.C.'s, if the tanks are properly cleaned when the contents are changed. Occasionally however, a chemical may permeate a tank wall and not be easily cleaned. The filling of the tank can then cause a cross contamination between the chemicals with unknown effects to the contents and the containers. Tanks and I.B.C.'s which are used for mixtures of chemicals are usually the most difficult to predict. This is because little information is available regarding the effects of chemical mixtures on container materials and materials used in the containers' components. Chemical attack of a container or its components can sometimes be seen during visual inspections. The environmental stress cracking inspection procedure is also useful in identifying chemical attack.

5. To what temperature variations has the tank been subjected?

Most polyethylene tanks and I.B.C.'s are designed to operate within an ambient temperature range of between 0°F and 100°F. Tanks are usually rated for a maximum temperature of about 130°F and a minimum temperature of approximately -40°F. Warmer temperatures accelerate the effects of U.V. radiation, and chemical attack while cooler temperatures usually don't. Tanks intended for use at temperatures between 100°F and 130°F are sometimes made with heavier walls to counter the effects of the warmer temperatures. Very high temperatures, above 130°F can cause the tank to soften and therefore lose structural strength. This softening can also lead to the tank expanding and stretching both can decrease the wall thickness causing the tank to weaken. This effect can in severe cases lead to tank failure. In less severe cases the long-term effects of a tank being overheated can lead to a shortened useful tank life. Tanks at very cold temperatures are generally the most brittle and therefore the most likely to be damaged by impacts. Periodic inspections can help to identify damaged tanks.

6. Has the tank been exposed to impacts?

Transport tanks such as I.B.C.'s, and portable tanks, are usually impacted more often than stationary tanks. Polyethylene tanks are very impact resistant. Occasionally an impact can exceed the tensile strength of the material causing permanent damage. Other impacts can cause gouges, cuts, and cracks. It is important to know that this damage has occurred so that it can be evaluated. Each impact and the damage it causes are unique. It is sometimes difficult to determine the extent of the damage without testing. In the case of impact damage it is better to remove a tank from service until a determination can be made of the extent of the damage.

7. Has the tank been pressurized or has it been subjected to an internal vacuum?

Polyethylene storage tanks are designed to operate with tank interior pressures, which equal the atmospheric pressure outside of the tank. Storage tanks are not designed for vacuum/pressure applications. I.B.C.'s and other transport tanks are usually designed and tested for a specific

Snyder Industries, Inc. Polyethylene Tank and I.B.C. Environmental Stress Inspection Guide
Original Issue date 9/18/00

pressure. This test pressure is marked on all UN marked I.B.C.'s. The test pressure is marked in kilopascals. In general the allowable pressure in an I.B.C. during transport is approximately 2/3 of the test pressure. Specific regulations regarding this are listed in Title 49 of the Code of Federal Regulations (49CFR). Snyder Industries, Inc.'s I.B.C.'s are designed for up to a ¼ psig vacuum. It is important that tanks and I.B.C.'s not be subjected to pressures or vacuums greater than the design criteria. Damage caused by pressure or vacuum can usually be seen during a visual inspection of the tank. However it is important to check for stress cracking which could have occurred. This cracking would be most easily found in areas of the tank that may have buckled or folded over during the time the tank was subjected to the pressure or vacuum situation.

8. Is the tank designed for the proper specific gravity?

The specific gravity of a material is the weight of the material compared to water. The weight of water is approximately 8.334 lbs. per gallon. Water has a specific gravity of 1.0. A material with a specific gravity of 1.5 would weigh 1.5 times as much as water per gallon. Therefore a material with a 1.5 specific gravity would weigh 1.5 times 8.334 which equals 12.50 lbs. per gallon. Polyethylene tanks, especially storage tanks are sold for use with different specific gravity materials. In most situations tanks designed for use with 1.5 specific gravity materials would be acceptable to store any chemical, which was compatible with the tank and components and weighed 12.50 lbs. per gallon or less. In most situations tanks designed for use with 1.9 specific gravity materials would be acceptable to store any chemical, which was compatible with the tank and components and weighed 15.83 lbs. per gallon or less. Materials with specific gravity's higher than the tank rating can be safely stored if the amount of material stored is reduced in relationship with the difference between the tank rating and the actual material weight. If the material weighed twice as much as the rated material for the tank you could safely fill the tank to ½ of its full capacity. Tanks which are filled with a material having a specific gravity close to the designed maximum specific gravity rating of the tank will need to be inspected more often than tanks which are filled with a material having a specific gravity of lower value if all other factors are equal.

What regulations might be involved which require a periodic inspection of the tank or I.B.C.?

Always check for city, county, state, and federal regulations, which may require you to inspect your tank on a regular basis, such as the requirements for a visual inspection of an I.B.C., to be performed as a part of the periodic retesting requirement. This requirement is in the Code of Federal Regulations Title 49 Part 180 Subpart D (180.352)(b)(2) and requires a visual inspection of I.B.C.'s, at least every 2.5 years. (For easy access to these regulations via the Internet to the Hazardous Materials Home Page at <http://hazmat.dot.gov/> then click on rules and regulations. In the case of rigid plastic I.B.C.'s an Environmental Stress Inspection should in the opinion of S.I.I. be a part of the required visual inspection. In the United States there is no requirement that rigid plastic I.B.C.'s be removed from service after a set period of time. Most other countries recognize a five, (5) year limit on the use of rigid plastic I.B.C.'s. The lack of a regulation specifically limiting the service life of rigid plastic I.B.C.'s in the United States places the responsibility for determining the useful life of the I.B.C. in the hands of the owner of the I.B.C. and/or the one who offers the container for transport. This means that in the case of rigid plastic I.B.C.'s, as with all other chemical transport tanks, knowledge of the condition of the tank is critical. As I.B.C.'s age the period between inspections required by the DOT regulations might be longer than the frequency needed for periodic environmental stress inspections. Depending on the chemicals involved, the exposure to ultraviolet radiation, and the other factors outlined above some tanks may need to be inspected more often to insure safety. In some cases a rigid plastic I.B.C.'s useful life could extend well past the five, (5) year limit. In other cases of extreme environmental conditions an I.B.C. might have a useful life of less than five, (5) years.

The key to safe utilization of tanks and I.B.C.'s is the ability to inspect that tank or I.B.C. with the knowledge required to make a valid evaluation of the condition of the container. Then based on that evaluation to take the required action to insure that only safe containers remain in use.

When the time comes to replace one of your IBC's, or your entire fleet – be sure to select your replacement tanks from the leader. Snyder's unique all polyethylene designs provide a multitude of benefits, including superior corrosion and chemical resistance, better impact strength, durability, proven performance and long-term reliability.

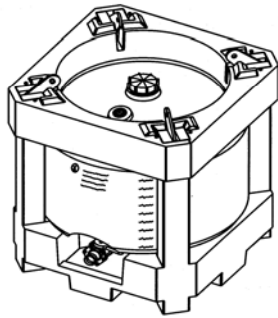

UN/D.O.T. certified UN31H1/HM-181E

Ultratainer

The ultimate in safety and durability. Ultratainer's revolutionary design combines the superior structural integrity of a cylindrical tank with the material handling benefits of a square IBC. Ultratainer is well suited for handling heavy materials up to 1.9 specific gravity (15.2 specific gravity)

Capacity	Tare Weight #	Length	Width	Height
330 Gal.	309 (437 HD)	46"	46"	70"
275 Gal.	289 (405 HD)	46"	46"	62"
220 Gal.	268 (374 HD)	46"	46"	54"

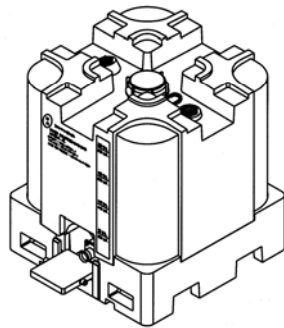

UN/D.O.T. certified UN31H2/HM-181E

Premium Square Stackable

The industry's best selling, all-poly, IBC provides an unparalleled value in long-term reusable IBCs for both hazardous and nonhazardous commodity liquids. Premium Square Stackable offers maximum features and component packages for a variety of applications.

Capacity	Tare Weight #	Length	Width	Height
330 Gal.	257	45"	45"	63.5"
275 Gal.	232	45"	45"	56"
220 Gal.	211	45"	45"	48.5"
120 Gal.	185	45"	45"	36.5"

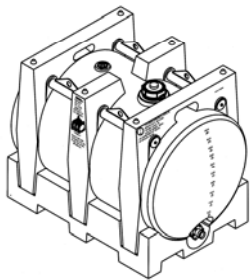

UN/D.O.T. certified UN31H2/HM-181E

Megatainer

Versatile and lightweight, the industry's largest poly-IBC system offers dependable transportation of bulk chemicals with reduced shipping and handling costs. Megatainer's 550 gallon capacity is suitable for both hazardous and nonhazardous liquids.

Capacity	Tare Weight #	Length	Width	Height
550 Gal.	570	81"	48"	60"

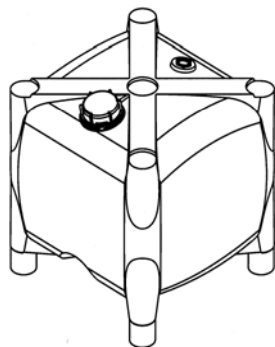

UN/D.O.T. Approved 31H2/Y

Excalibur

Snyder's latest product innovation, is the lowest cost plastic IBC design. The most economical plastic IBC delivers the industry's highest useful-life-to-cost ratio.

Load Rating	Capacity	Weight #	Length	Width	Height
1.35 S.G.(UN31H2)	330 Gal.	180	45"	45"	52"
1.9 S.G.(UN31H2)	330 Gal.	220	45"	45"	52"