

**120 EXCALIBUR 1.35 SP. GR. "STANDARD PACKAGE OF OPTIONAL EQUIPMENT"**

U.N. MARKING ON TANK READS:

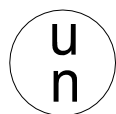

31H2 / Y / MO. / YR. / USA  
 SNYDER IND. INC.  
 LINCOLN, NE. 1163 / 646  
 CAPACITY - 454 LITERS  
 TARE MASS - ACTUAL KG  
 GAUGE TEST PRESSURE - 100 KPA  
 LAST LEAKPROOFNESS TEST - MO. / YR.  
 LAST INSPECTION - MO. / YR.

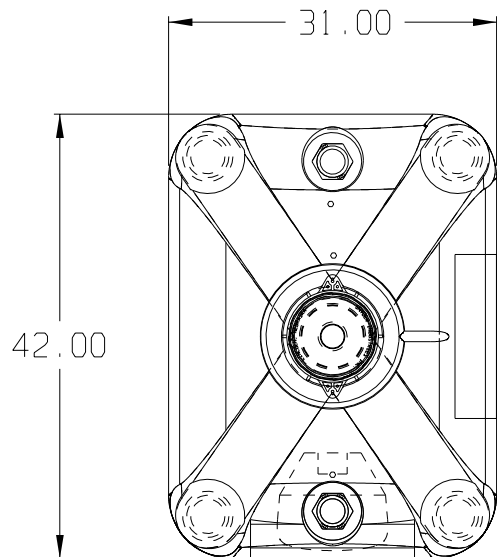

ITEM #	DESCRIPTION	QTY.	PART NUMBER
1	TANK - 2 BUNG TANK WITH 6.5" CAP AND BOTTOM DRAIN HDPE NATURAL. (WITH CAP LANYARD INSERT AND WITH TAMPER EVIDENCE INSERTS MOLDED IN)	1	65639
2	FEET - THREADED HDPE BLACK	4	65049
3	S.I.I. PROPRIETARY 2" NPS REPLACEABLE BUNG GLASS FILLED POLYETHYLENE W/ITON O-RING SEAL	2	N/A
4	2" NPS RIEKE POLYETHYLENE BUNG PLUGS WITH EPDM FLAT GASKETS	1	347340
5	6.5" GEM CAP WITH 2" NPS CENTER OPENING AND EPDM CAP GASKET. EQUIPPED WITH LID TIE	1	347795
6	S.I.I. 2" NPS VACUUM RELIEF VENT WITH EPDM DISK AND FLAT GASKET (AVERAGE GRAVITY FLOW RATE OF 70 GALLONS PER MINUTE)	1	347854
7	2" BANJO STANDARD PORT GLASS FILLED POLYPROPYLENE BOTTOM DRAIN VALVE WITH TEFLON SEATS AND BALL AND 18/8 S.S. BOLTS. INCLUDES DUST CAP AND CAP LANYARD.	1	347718

I.D. FILLNECK OPENING 6.25"

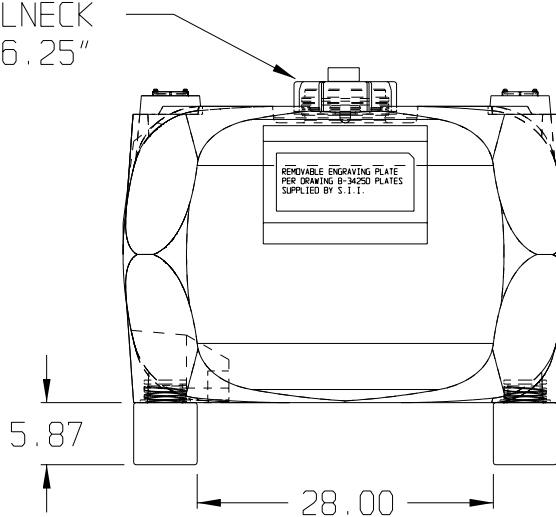
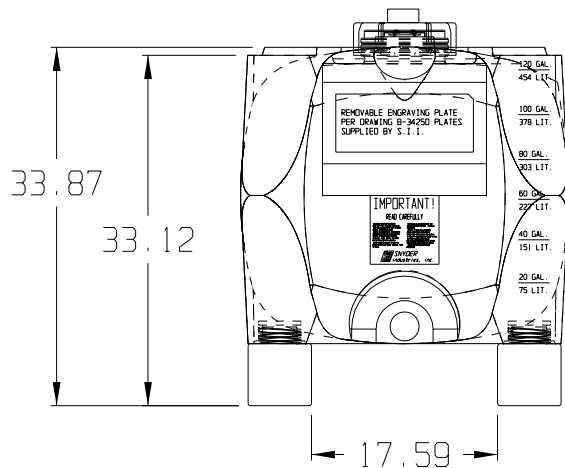

(all dimensions in inches)

TANK PART#: 65639 @ 1.35 SPGR

120 GALLON 1.35 SPECIFIC GRAVITY EXCALIBUR TANKS

REF#: 0000

08/19/02

SNYDER INDUSTRIES INC.