

Saf-Tainer

“Protect your company against hazardous IBC spills with the portable, cost effective protection of Saf-Tainer” It’s the most cost effective system on the market today. The unique polyethylene design reduces the risk of unrecoverable spills and protects the environment. It’s economical price and versatile design saves you money while safely addressing your company’s ever-changing environmental concerns.



Drain Plug allows easy emptying and cleaning.



Forklift Channels make Saf-Tainer easy to move and stack.

Benefits:

- Meets 40 CFR 264.175 which satisfies containment regulations
- 100% polyethylene construction which offers superior corrosion and chemical resistance.
- 8000 lb. static load capacity which allows it to handle heavier loads
- Sump with drain plug making it easy to drain and clean
- Portable and lightweight allows you to move Saf-Tainer where it’s needed



Saf-Tainer is compatible with all poly IBCs



8000 lb static load capacity allows stacked discharge arrangements



Optional top grating makes Saf-Tainer compatible with all IBCs, including metal



Internal platform can also be used as IBC stand

Email: sales@snydernet.com • www.snydernet.com



Saf-Tainer's economical price and versatile design saves you money while safely addressing your company's ever-changing environmental concerns.

Removable internal platform can be used as an IBC stand.

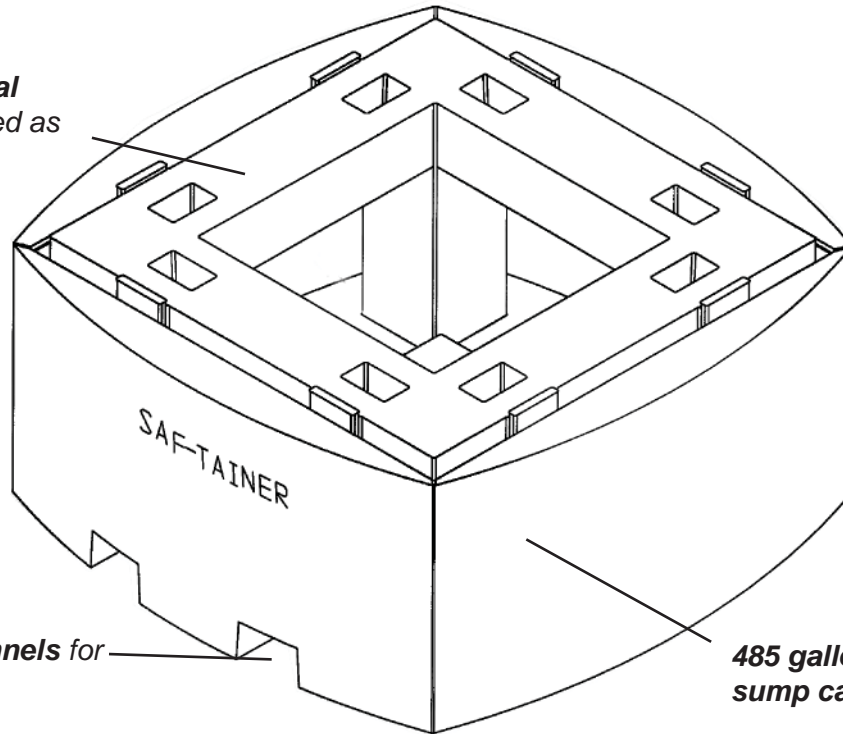

Forklift channels for portability.

485 gallon sump capacity.

FRP grating may be required with metal IBCs.

Component	Dimensions	Weight	Loading Bearing Capacity	Liquid Capacity
Basin	L= 66" W=66" H=29 1/2"	92 lbs.		500 Gallons
Stand	L=52" w=52" H=30"	190 lbs.	8,000 lb. load	
Stand/Basin	L=66" w=66" H=30"	282 lbs.	8,000 lb. load	485 Gallons

Intermediate Bulk Containers Division • P.O. Box 4583 • Lincoln, NE • 68504
Phone: 402-467-5221 • Fax: 402-465-1220 • Email: sales@snydernet.com