

PREMIUM 220 SQUARE STACKABLE "STANDARD PACKAGE OF OPTIONAL EQUIPMENT"

ITEM	DESCRIPTION	QTY	P/N
1	220 GAL TANK W/ 6" CAP, (2) BUNG LOCATIONS [(1) STRAIGHT (1) ANGLED], AND 2" BOTTOM DRAIN - NATURAL [HDLPE]	1	66345
2	PREMIUM BASE - 4 WAY FORKLIFT ACCESS - RED [HDLPE]	1	62123
3	SII PROPRIETARY 2" NPS REPLACEABLE BUNG W/ VITON O-RING SEAL - [GLASS FILLED PP]	2	34100008 33100039
4	2" NPS RIEKE BUNG PLUG WITH EPDM GASKET - [PE]	2	34700340
5	6" HEAVY DUTY CAP W/ 2" NPS CENTER OPENING AND EPDM GASKET - [PE] INCLUDES LANYARD	1	34700391
6	SII PROPRIETARY 2" VACUUM RELIEF VENT WITH EPDM DISK AND GASKET - [PE] AVERAGE GRAVITY FLOWRATE OF 70 GAL/MIN	1	34700854
7	2" BANJO STANDARD PORT BOTTOM DRAIN VALVE WITH TEFLON BALL AND SEATS AND 18/8 SS BOLTS [GLASS FILLED PP] INCLUDES DUST CAP AND LANYARD	1	34700718

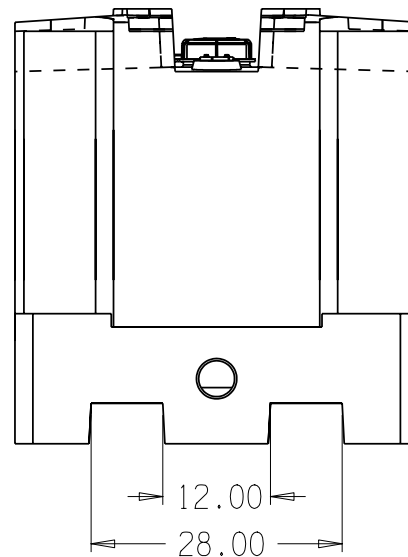

UN MARKING READS :

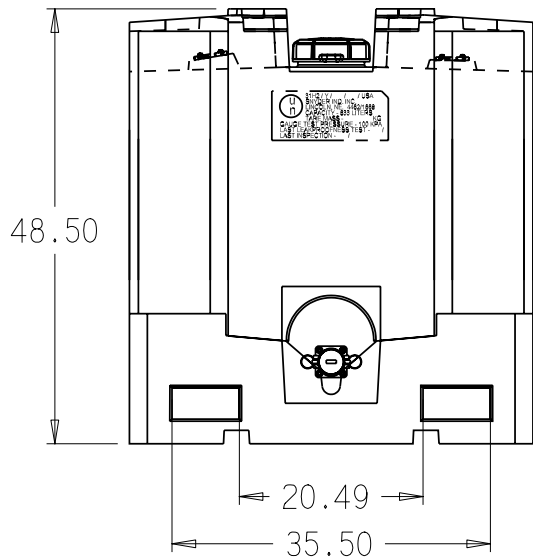
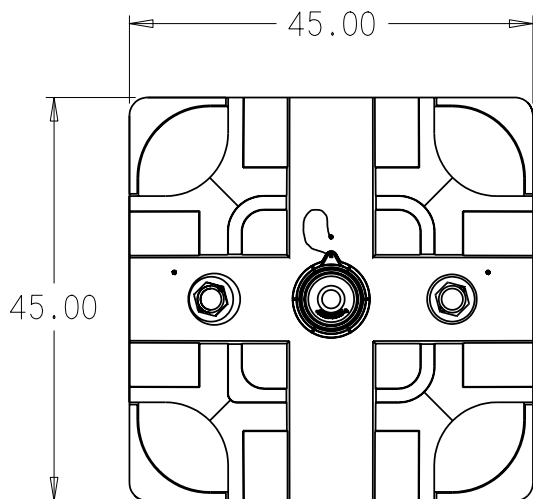
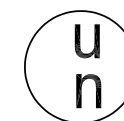

31H2 / Y / / / USA
 SNYDER IND. INC.
 LINCOLN, NE. 4462/1668
 CAPACITY - 833 LITERS
 TARE MASS - KG
 GAUGE TEST PRESSURE - 100 KPA
 LAST LEAKPROOFNESS TEST - /
 LAST INSPECTION - /

(all dimensions in inches)

PART # TANK: 66345

PREMIUM 220 GALLON SQUARE STACKABLE IBC

REF#: 0000

01/04/11